

GP-2600 **SLIPFORM PAVER**



GOMACO

The Worldwide Leader in Concrete Paving Technology

DESIGNED TO MEET WORLDWIDE DEMANDS IN SLIPFORM PAVING

SUPERIOR QUALITY AND TECHNOLOGY THAT NO ONE ELSE CAN OFFER

JUST A FEW OF THE FEATURES THAT MAKE THE GP-2600 “NUMBER ONE”

- **High Production...** Optimum engine performance with the emission-controlled engine and plenty of horsepower provides high production.
- **Less Noise and More Cooling Capacity...** The engine package design provides the operator with one of the quietest operations available today. The cooling capacity provides a low hydraulic oil temperature, which results in longer life of parts and reduced operating cost.
- **Push-Button Steering Setup...** “Smart” cylinders provide push-button steering control setup and easy operation on the four-track machine.
- **Accurate and Quick Mold Positioning...** The T-Beam mounting rail provides positioning of the mold and the quick mounting and removal of the mold on the jobsite.
- **Versatility in Changing Paving Widths...** The modular frame hydraulically telescopes on the left side up to 6 ft. 6 in. (1.98 m).
- **Proven Rideability...** Superior rideability results have been job-proven time and time again by contractors throughout the world.
- **Ease of Operation and Service...** Award winning and exclusive G21 operating system features user-friendly controls and system diagnostics. The electronic-over-hydraulic system provides easy, accurate adjustment with an instant, controlled response.
- **Less Maintenance Time...** Fiberglass shroud lifts for easy access to the engine and service points.
- **Visibility Means Safety...** Lower profile engine shroud, full operational platform, and guard rails provide the operator with enhanced visibility of the entire operation.
- **More Safety and Minimum Clearance...** 3-position pivoting ladder allows variable degrees of angle for safety and ease in climbing for access to the operator’s platform. The ladder can be vertically positioned tight to the machine for minimum-clearance paving conditions.
- **Mobility and Transportability Made Easy...** Unique counter-rotation feature provides 360 degree turns within the machine’s own dimensions. The selective steer system on the four-track machine features versatility for easy job-site mobility. The GP-2600 has one of the fastest tracking speeds in the industry.
- **High-Performance Drive System...** The hydraulic engineering and choice of quality vended parts provide a unique two-speed drive system with a powerful, low speed for pushing large volumes of concrete.
- **Unparalleled Accuracy...** GOMACO’s hydraulically powered transition adjuster (PTA) provides accurate, on-the-go transitions for the crown of the concrete slab.

The job-proven GOMACO GP-2600 is preferred by contractors throughout the world. All of the features that have made the GP-2600 the “Number One” mid-range paver in universal paving markets are still standard. The GP-2600 has even more outstanding features that provide today’s contractor with the ultimate paving machine of the future.

GOMACO provides the highest standard of quality in the industry with skilled personnel producing state-of-the-art machines. The GP-2600 mid-range paver is built with durability for construction job-site conditions. Quality control from GOMACO engineering through manufacturing provides low-maintenance equipment with superior paving performance. Safety standards are a priority in equipment designs.

The engineering teams have designed the GP-2600 for maximum versatility with proven rideability results. GOMACO has provided quality, versatility, proven performance, and dedication to customer satisfaction for over 40 years and will continue to meet the challenges of today and into the future.



HW-110306-D31

The GP-2600 slipform paver is designed to meet the world-wide demands in new and reconstruction of highways, streets, parking lots, and airport pavements. This slipform paver is available with two or four tracks to meet varying applications and contractor preference.

The GP-2600 modular telescoping frame provides versatility. The GP-2600 provides contractors with a broad range of paving widths from 12 ft. (3.66 m) to 18 ft. 6 in. (5.64 m) with the unique telescoping frame that extends 6 ft. 6 in. (1.98 m) on the left side. The GP-2600 will pave widths up to 32 ft. (9.75 m) with additional frame inserts. Hydraulically pressure-compensated sideplates provide edge control and a paving depth up to 19 in. (483 mm).

Production and serviceability are key factors with the GP-2600. Over 10 percent more fuel capacity combined with engine fuel efficiency provide an extended day of paving, resulting in higher production. The segmented fiberglass shroud provides ease in serviceability. One section lifts up to allow easy access to the engine and service points.



HW-110311-D29

The low-profile engine shroud designed for the GP-2600 provides enhanced rear visibility for the operator. This allows the operator to remain at the controls and see the entire paving operation. The GP-2600 is powered by a 275 hp (205.2 kW) Caterpillar, emission-controlled diesel engine.

An optional removable auger/strike-off offers ease in changing widths and transportability. The detachable telescoping auger/strike-off gives contractors the benefit of a mold that can be either an open-front or auger/strike-off. It can then easily be broken down with removable and telescoping sections. The auger/strike-off is designed to move independently with hydraulically-adjustable mounts on the front of the mold. A self-supporting transition adjuster (TA) is standard to allow for crowning. Both the strike-off and the augers have 6 ft. (1.83 m) of telescoping capabilities to aid in changing paving widths. When paving widths need to be changed, the contractor only has to add or remove a section of the paving mold and then telescope the auger and strike-off in or out, depending on the needed width.

The telescoping auger incorporates bolt-on flighting to accommodate the changing widths. Along with giving the contractor some extra versatility with their pavers, the detachable telescoping auger/strike-off can ease transportation. The auger/strike-off can be detached from the front of the mold and the wings on the sideplate can be folded in to allow a four-track paver, with the mold still mounted underneath it, to be transported on one truck under 12 ft. (3.66 m) wide.



HW-110307-D22

The Digital Power of GOMACO's Exclusive G21 Operating System

- **G21 is GOMACO's award-winning, proprietary software and control system...** GOMACO was recognized for its commitment of resources to the development of this revolutionary software and operating system that combines intelligence with simplicity for GOMACO construction equipment. It is one of the few operating systems awarded a Top 100 Award from *Construction Equipment* magazine and a Top Innovations Award from *Equipment World* magazine. The G21 operating system is exclusive to GOMACO.

- **GOMACO's exclusive G21 digital operating system features a universal design that is simple to read and easy to understand...** Easy operation is provided with variable control dials and various function switches.

- **Red LED display is featured...** This provides a user-friendly operation and high visibility for monitoring deviation meters.

- **Less downtime and quicker uptime on service...** Advanced system diagnostics of the G21 automatically pinpoint and identify electrical circuit opens, shorts and fault codes to aid in troubleshooting. The G21 helps eliminate service time in searching for system problems.

- **A two-line display...** A two-line, 24-character, backlit liquid crystal display (LCD) allows the operator to view and monitor numerous active codes. Linked to the electronic control system and its sensors, the panel communicates setup and operation messages.

- **More room for future expansion...** than any CAN controller on the market for machine control. Compatible with industry standard J1939 CAN network. Twenty times more program memory for the many features available in today's market plus expansion capabilities for the future. Interfaces with stringless technology/3-D control systems and laser technology. True network architecture enhance expandability to communicate with external computer systems. Laptop computer systems can be connected for software updates, data monitoring and future data logging capabilities.



EG-120204-D2

GOMACO'S SELECTIVE STEER CONTROLS

FEATURING STEERING CHOICES FOR JOB-SITE MOBILITY AND TRANSPORTABILITY ON FOUR-TRACK PAVERS

GOMACO's Selective Steer Controls feature a forward/reverse steer switch and a position switch used to select the stringline steer mode or one of the other steering modes with the steering control dial for manual track steering.



Stringline Steer Mode ... This mode is selected when steering is to be controlled by the steering sensors. The controller automatically recognizes where the sensors are plugged in and assigns steering, slope, or dual stringline to the appropriate tracks and display meters.

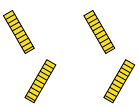

Coordinated Steer ... For minimum turning radius. When the steer select switch is in the "coordinated steer" position, the steering control dial will control the turning of the tracks. When the dial is in the center position, the tracks will be straight ahead. If the dial is turned left or right from the center position, the leading tracks will turn in the corresponding direction and the trailing tracks will turn in the opposite direction.

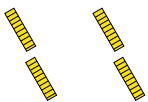

Crab Steer ... Walk sideways for ease in putting machine on line. When the steer select switch is in the "crab steer" position, the steering control dial will control the turning of the tracks. If the dial is turned left or right from the center position, all tracks will turn in the corresponding direction to walk the machine to the side.

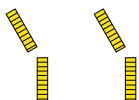

Front Steer ... When the steer select switch is in the "front steer" position and the steering control dial is turned left or right from the center position, the front tracks will turn in the corresponding direction and the rear tracks will remain straight.

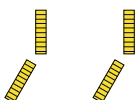

Rear Steer ... When the steer select switch is in the "rear steer" position and the steering control dial is turned left or right from the center position, the rear tracks will turn in the corresponding direction and the front tracks will remain straight.

GOMACO's Control System Easily Interfaces With New Stringless Technology

GOMACO Corporation has the control system of the future. The G21 technology allows GOMACO's slipform pavers, trimmers, and placer/spreaders to be controlled by an automated 3-D machine-control system and not by stringline. The 3-D control system is adaptable to the exclusive G21 control system. This system can accommodate radii or superelevations automatically according to design data.

Real-time navigation systems allow the project data created in the CAD system to be directly put into the paving process. There is no stringline installation or maintenance. **The stringless control systems can save you time and money.**



HW-030103-D2



HW-030102-S-24

Three frame-mounted bar inserters on the front of this machine accurately place the transverse bars for the longitudinal joints. The inserters place the bars behind the vibrators. The front split auger on the GP-2600 spreads the concrete to a predetermined width. Both the right-hand and left-hand drive sections are independently controlled with variable speeds up to 62 rpm, for quick and accurate spreading of the concrete.



HW-060004-D12



HW-080413-D1

This versatile four-track GP-2600, equipped with the GOMACO Auto-Float® slipforms mainline paving in Salt Lake City, UT.

GP-2600 with Job-Proven Superior Rideability Results from Around the World



HW-060413-D23

The GP-2600 is capable of paving up to 32 ft. (9.75 m) wide and slab depths of 19 in. (483 mm). GOMACO's unique high-performance drive system delivers plenty of power for pushing and forming the concrete.



HW-060413-D3

This two-track GP-2600 slipforms airport aprons 16 ft. 4 in. (4.98 m) wide and 17.7 in. (450 mm) thick on the new Bangkok International Airport in Bangkok, Thailand. This machine is equipped with the GOMACO Auto-Float®.



HW-000509-21-21A

This versatile four-track GP-2600 slipforms a 24 ft. (7.32 m) wide concrete roadway near Cochabamba, Bolivia.



HW-060407-D23

The two-track GP-2600 is slipforming a cul-de-sac with a 95 ft. (29 m) inside radius. This machine is equipped with three frame-mounted bar inserters. This street in Wayne, NE, is being slipformed full width with integral curb on both sides.

V E R S A

BAR INSERTION SYSTEMS DESIGNED TO FIT YOUR PROJECT SPECIFICATIONS

GOMACO offers several bar insertion systems that are designed to accommodate your project specifications. Hydraulic cylinder, air-powered and manual insertion are the three types of bar insertion. Bar inserter attachments include the frame-mounted, mold-mounted, sidemounted, and trailing form. GOMACO's bar inserters provide easy and accurate bar placement at an exact job specification.



HMV-099406-11

Frame-Mounted Bar Inserter

The frame-mounted bar inserter accurately places the transverse bar for the longitudinal joint. The inserters place the bars behind the vibrators. The bar spacing is determined by a timing wheel mounted to the crawler track.



29E-92-8-B1

Female keyway with hydraulic side bar insertion and vibration to the bar.

The hydraulic system includes vibration to the bar. Vibration is applied to the bar during insertion, which provides consolidation of concrete around the bars. This system requires one vibrator circuit. The minimum slab depth required is 12 in. (305 mm) and the maximum bar length is 30 in. (762 mm).



HMV-069206-2A-3

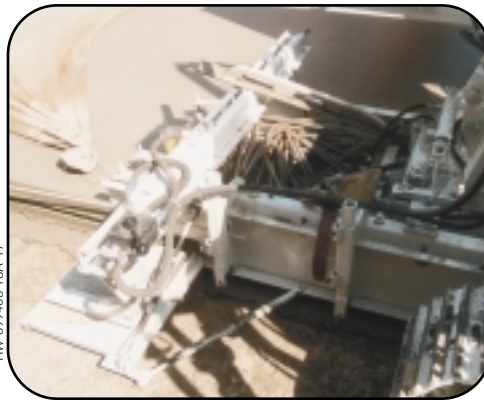

HMV-099408-16A-17

Trailing Form With Air-Powered L-Bar Insertion

The trailing form with air-powered or manual bar insertion is designed to trail the track on two-track pavers. This system will accommodate most types of bars.



HMV-069509-20A

Trailing Form With Manual L-Bar Insertion



HMV-099305-7

(Pictured Above) Sideplate Extension With Air-Powered L-Bar Insertion.



CG-069509-1A

(Right Photo) GOMACO's Air-Powered Side Bar Insertion For Male Keyway.

T I L I T Y

UNPARALLELED ACCURACY WITH THE GOMACO POWER TRANSITION ADJUSTER (PTA)

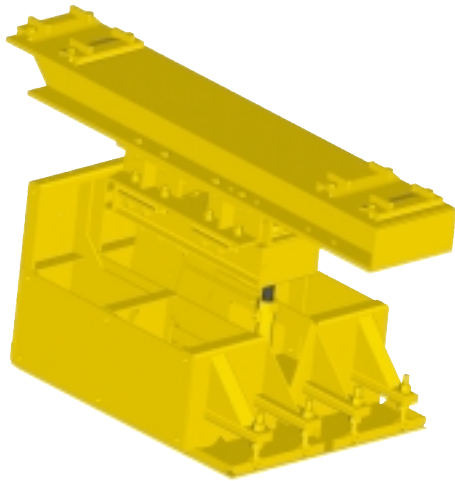

GOMACO's hydraulically powered transition adjuster (PTA) provides on-the-go transitions in the crown of the concrete slab.

A switch in the operator's console controls the PTA in a positive or negative (up or down) motion. This eliminates the crown in the paving mold/slab or brings the crown back into the mold/slab. These transitions are necessary in paving through superelevations and intersections. This simple solution provides an easy method for an operator to perform a smooth transition where necessary and accomplish the required slab profile as specified.



The illustration above shows a stretch of roadway with a 3 in. (76 mm) crown to a zero (0) crown into a superelevation and out from zero (0) crown to a 3 in. (76 mm) crown. The operator has dialed in a minimum crown of zero (0) and a maximum crown of 3 in. (76 mm). The encoder wheel assemblies positioned on two of the tracks measures the distance of the two track lines inside and outside of the slab. The transition computer automatically averages these two distances to the total change from minimum to maximum crown over the total distance entered for the transition.

GOMACO'S COMPUTERIZED TRANSITION ADJUSTER

GOMACO offers a computerized transition adjuster that meets the increasing demands for a smooth riding surface. The optional specialized computer control allows for smooth transitions from a crown to a flat cross slope in a superelevation, or vice versa, calculating the number of steps to make the transitions.

The computer controls and synchronizes the power transition adjuster (PTA) on the paver to make the necessary adjustments as specific stations are reached in the transition.

GOMACO'S SENSOR EQUIPMENT IS RELIABLE AND COST EFFECTIVE

Sensor line and sensors provide the grade and steering information linked to the GOMACO G21 digital operating system, located on the operator panel.

The GOMACO electronic-over-hydraulic sensor system provides intelligent control of grade and steering for paving accuracy, superior rideability and ease of operation.

GOMACO sensor line is designed specifically for electronically controlled equipment. GOMACO line rods are 3/8 in. (9.5 mm) diameter plated steel. The 18 in. (457 mm) length of the line rods allow an adjustment range of 12 in. (305 mm) for sensing accuracy. The line rod clamps are rustproof and durable, made of solid aluminum.

GOMACO's 48 in. (1219 mm) long sensor line stakes are machine tapered for easy driving and fast setup. The 3/4 in. (19 mm) diameter stake resists bending.



STRINGLINE ACCESSORIES

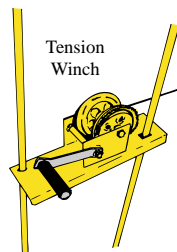
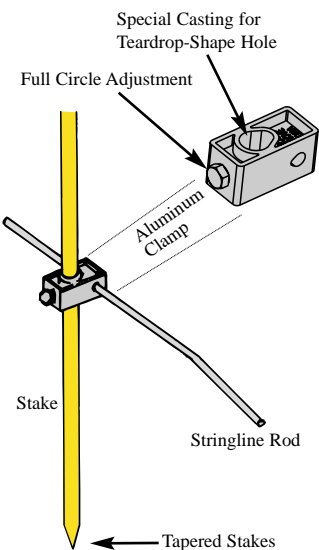

The line tension winch has a 3-to-1 gear ratio for tightening the line. The winch has a 1000 lb. (454 kg) pull capacity and mounts on two 48 in. (1219 mm) by 3/4 in. (19 mm) stakes. The winch reel holds 370 ft. (112.8 m) of 1/8 in. (3 mm) line.

ULTIMATE PAVING SYSTEMS

GOMACO OFFERS BOTH THE AUGER/STRIKE-OFF MOLD AND THE EXCLUSIVE OPEN-FRONT MOLD

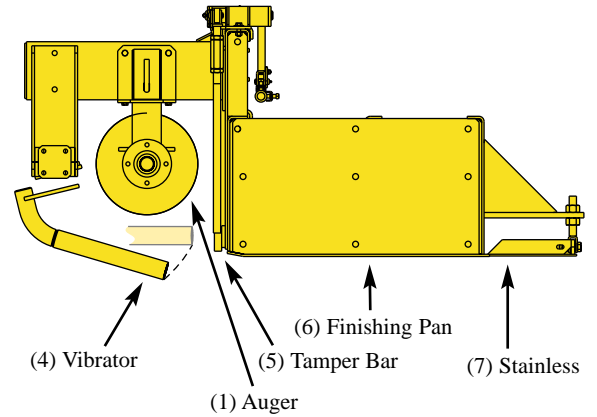
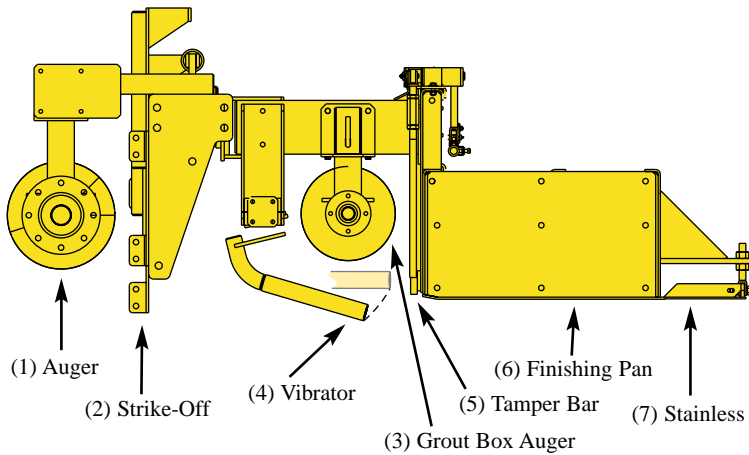

- (1) The front **split auger** serves to spread the concrete to a predetermined width. The right-hand and left-hand drive sections are independently controlled with variable speeds up to 62 rpm.
- (2) The **strike-off** is split for full, independent control. Both strike-off plates can be vertically controlled on the right and left sides, to meter material into the mold.
- (3) The GOMACO **grout box auger** is for control of material through transitions or superelevations.
- (4) **Vibration** is provided to the throat area of the mold for consolidation of concrete. The vibrators, with an automatic on/off control, activated with machine movement, are hydraulically powered with variable speeds up to 10,500 vpm. The vibrator positioning is hydraulically controlled for ease in start-up and finish.
- (5) The GOMACO **tamper bar** system tamps down the aggregate even with the surface of the pan, and assists in consolidation. The tamper bar is hydraulically powered with an automatic on/off control, activated with machine movement.
- (6) The **finishing pan** serves to level the concrete.
- (7) Adjustable **stainless steel** is exclusive to the GOMACO system. This seals the voids and provides the troweled GOMACO finish out of the mold.

Molds Available for the GP-2600

- 3100 series open-front mold with a 14 in. (356 mm) auger and a maximum speed of 66.8 rpm @ 24 gpm (90.8 Lpm) flow.
- 3100 series auger/strike-off mold with a 16 in. (406 mm) front auger and a maximum speed of 62.1 rpm @ 24 gpm (90.8 Lpm) flow and a 14 in. (356 mm) grout box auger with a maximum speed of 13 rpm @ 4.5 gpm (17.03 Lpm) flow.
- 5000 series open-front mold with a 16 in. (406 mm) auger and a maximum speed of 47.8 rpm @ 24 gpm (90.8 Lpm) flow.
- 5000 series auger/strike-off mold with a 20 in. (508 mm) front auger and a maximum speed of 29.5 rpm @ 24 gpm (90.8 Lpm) flow and a 16 in. (406 mm) grout box auger with a maximum speed of 6.5 rpm @ 4.5 gpm (17.03 Lpm) flow.

The 3100 series mold and stainless from front to back is 48 in. (1219 mm) and the 5000 series mold and stainless is 60 in. (1524 mm).

EDGE SLUMP CONTROL FROM GOMACO

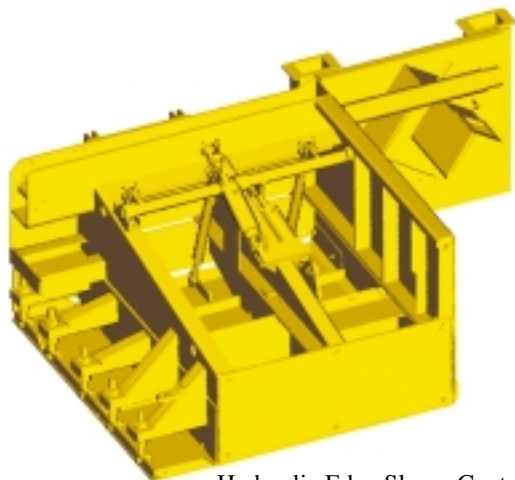

Hydraulic Edge Slump Control

THE SUPERIOR GOMACO EDGE



GOMACO offers edge slump control to accommodate slump and mix design. Edge slump control is available in hydraulic or manual adjustments in the mold.

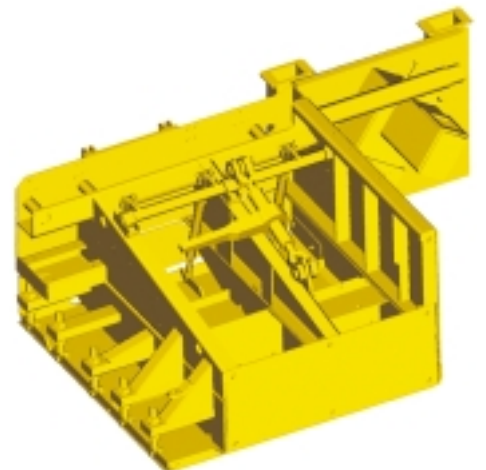

Manual Edge Slump Control

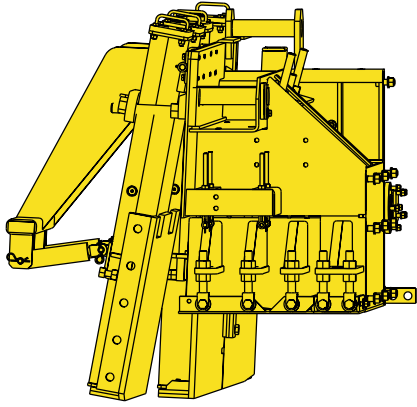

V ertical H inged S ideplates

GOMACO's Vertical Hinged Sideplates have hydraulic control for ease in start-up from an existing slab. The 4 in. (102 mm) cylinder stroke allows the split sideplates to open and close. This provides less labor and a smoother transition to the new slab. The Vertical Hinged Sideplates can be raised or lowered up to 19 in. (483 mm) to negotiate headers and other obstacles. The Vertical Hinged Sideplates are for four-track pavers only.



Integral Curb

A high-production feature on GOMACO slipform pavers is one-pass slipforming with **integral curb on one or both sides** of the slab.

GOMACO AUTO-FLOAT®

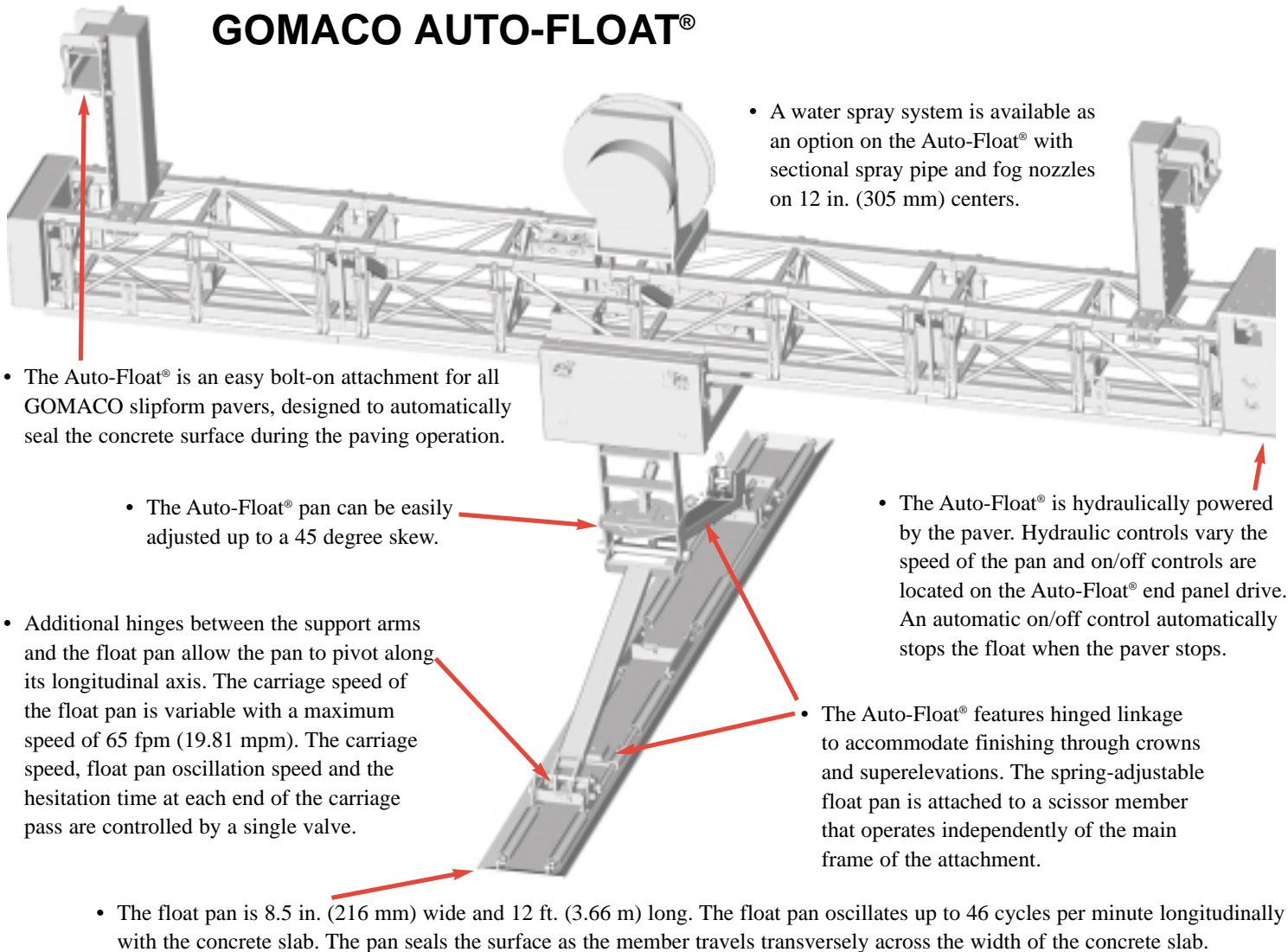

- A water spray system is available as an option on the Auto-Float® with sectional spray pipe and fog nozzles on 12 in. (305 mm) centers.
- The Auto-Float® is an easy bolt-on attachment for all GOMACO slipform pavers, designed to automatically seal the concrete surface during the paving operation.
- The Auto-Float® pan can be easily adjusted up to a 45 degree skew.
- The Auto-Float® is hydraulically powered by the paver. Hydraulic controls vary the speed of the pan and on/off controls are located on the Auto-Float® end panel drive. An automatic on/off control automatically stops the float when the paver stops.
- Additional hinges between the support arms and the float pan allow the pan to pivot along its longitudinal axis. The carriage speed of the float pan is variable with a maximum speed of 65 fpm (19.81 mpm). The carriage speed, float pan oscillation speed and the hesitation time at each end of the carriage pass are controlled by a single valve.
- The Auto-Float® features hinged linkage to accommodate finishing through crowns and superelevations. The spring-adjustable float pan is attached to a scissor member that operates independently of the main frame of the attachment.
- The float pan is 8.5 in. (216 mm) wide and 12 ft. (3.66 m) long. The float pan oscillates up to 46 cycles per minute longitudinally with the concrete slab. The pan seals the surface as the member travels transversely across the width of the concrete slab.

HW-060304-D17

GP-2600

Two-Track

- Two-track illustrations and dimensions show 12 ft. (3.66 m) wide 3100 series open-front mold, series two tracks, and 8 in. (203 mm) slab depth.

- A. 7.97 in. (202 mm)
- B. 15.75 in. (400 mm)
- C. 11.25 in. (286 mm)
- D. 34.97 in. (888 mm)

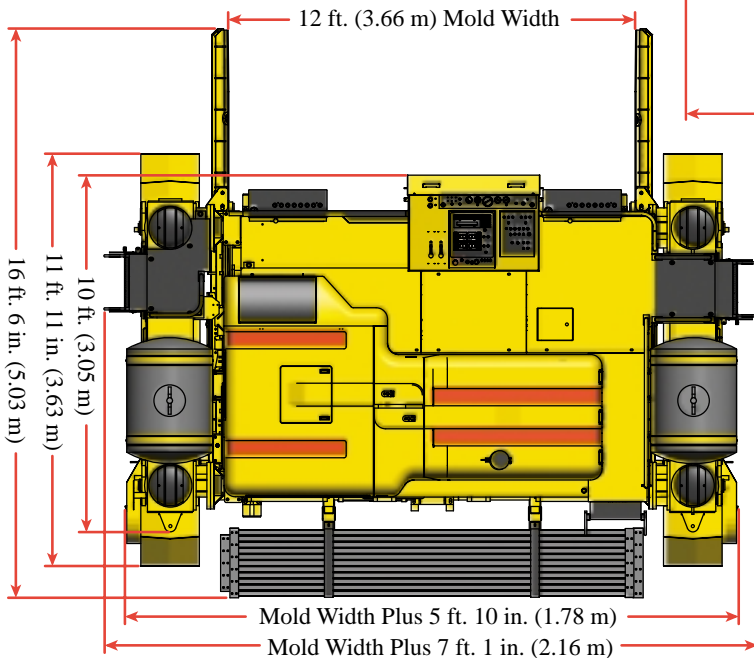
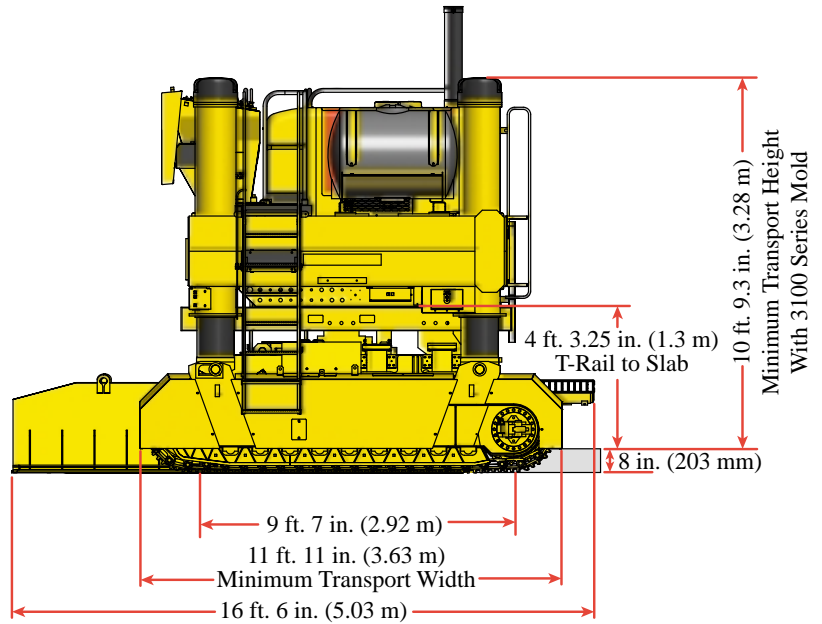
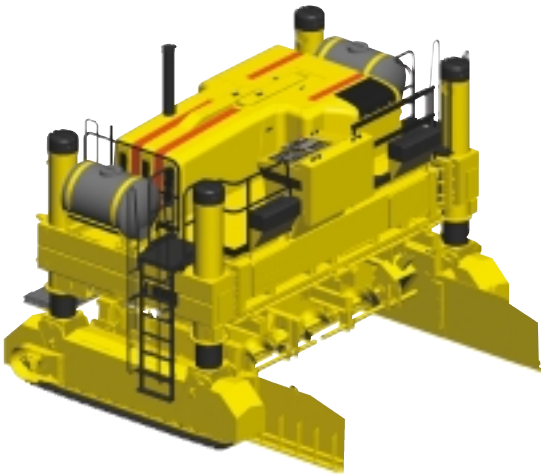
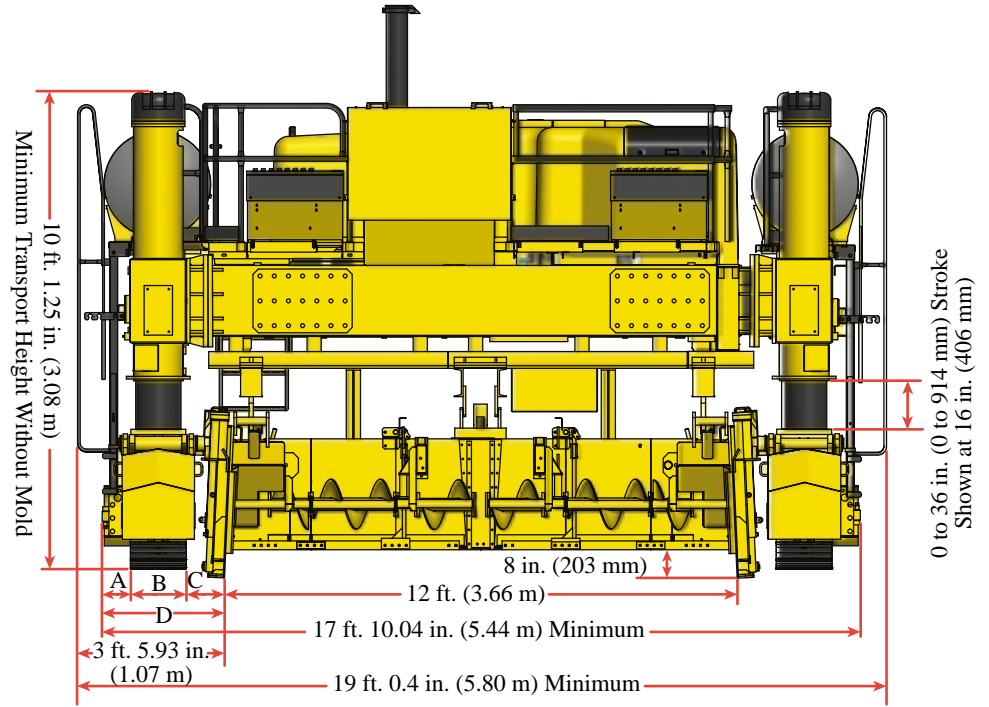

Transportability is an important feature in the design of the GOMACO GP-2600.

The two-track minimum transport width is 11 ft. 11 in. (3.63 m) and the four-track minimum transport width is 9 ft. 10 in. (3 m). The two-track minimum transport height is 10 ft. 1.25 in. (3.08 m) without the mold and 10 ft. 9.3 in. (3.28 m) with the series two mold. The four-track minimum transport height is 10 ft. 2 in. (3.1 m) without the mold and 10 ft. 7.5 in. (3.24 m) with the 3100 series two mold. The rear work bridge on the paver is hinged to allow it to fold up during transport. This allows the track legs to be inside the frame depth or transport width of the paver. By maintaining a minimum transport width, job-to-job mobility is easier, safer, quicker, and cost effective.

GP-2600 Four-Track

- Four-track illustrations and dimensions show 12 ft. (3.66 m) wide 5000 series auger/strike-off mold, series two tracks, and 8 in. (203 mm) slab depth.

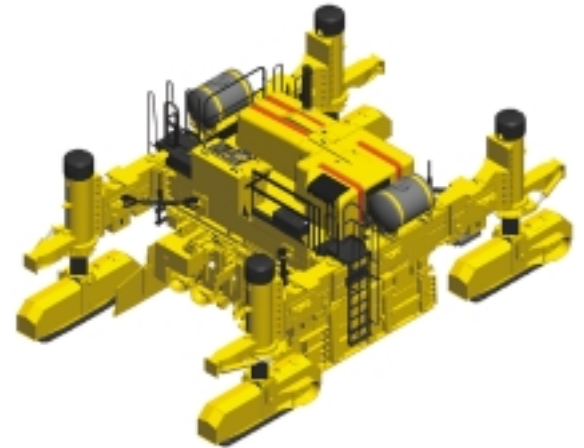
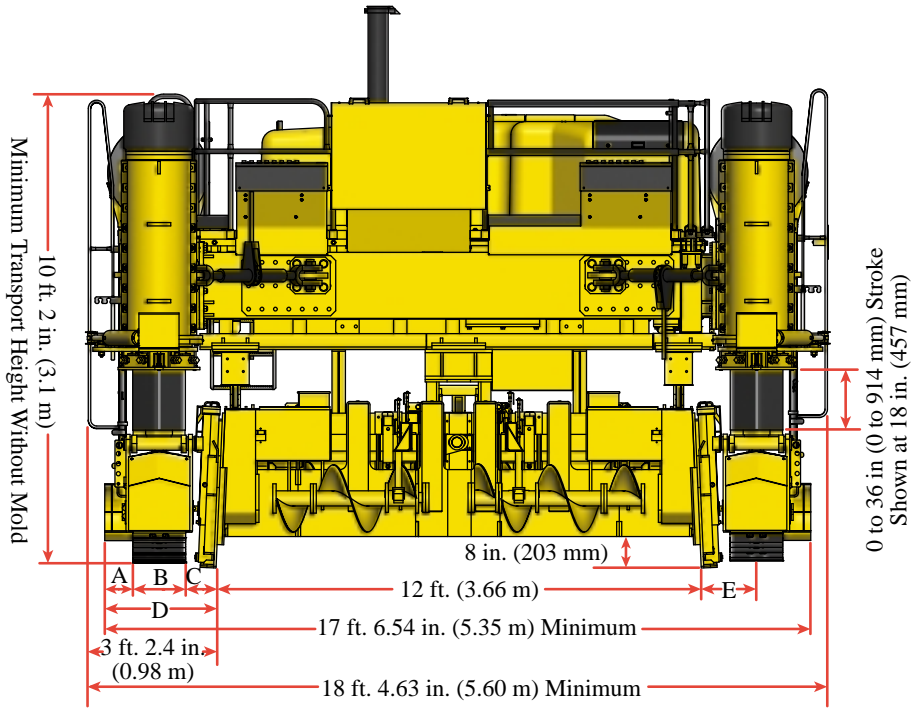

- A. 8.38 in. (213 mm)
- B. 15.75 in. (400 mm)
- C. 9.12 in. (232 mm) minimum clearance to allow 5 degree maximum steer angle
- D. 33.25 in. (845 mm) minimum clearance to allow 5 degree maximum steer angle
- E. 17 in. (432 mm) minimum clearance to allow 5 degree maximum steer angle

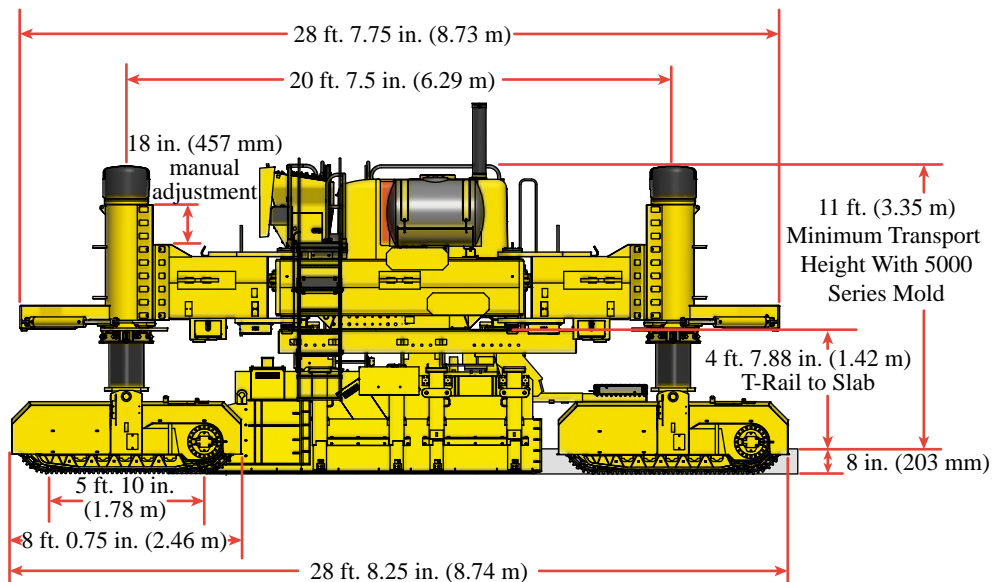
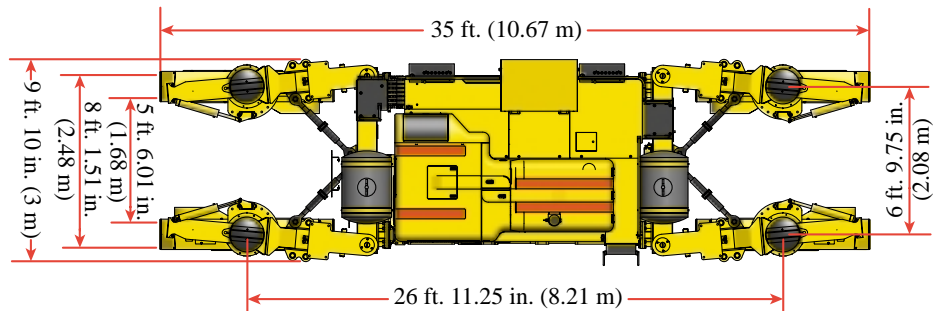
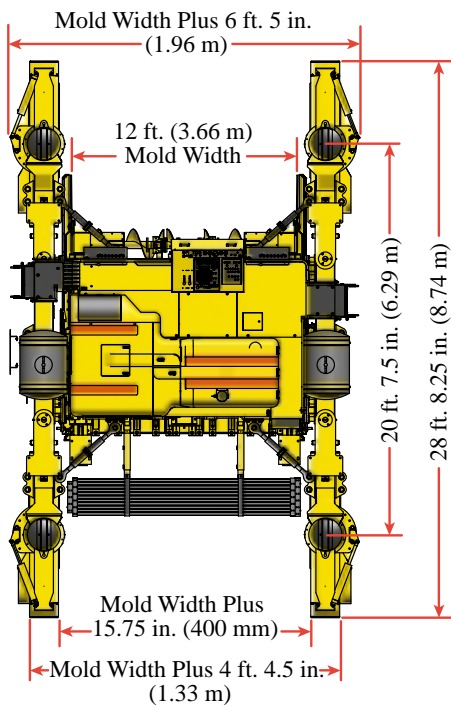

GP-2600 Slipform Paver Specifications

ENGINE

Type: Caterpillar diesel engine (emission controlled)
Power: 275 hp (205.2 kW) @ 2200 rpm.
Fuel economy: 11 gph (41.6 Lph) @ 80% of rated hp.

SERVICE CAPACITIES

Fuel reservoir: 150 gal. (567.8 L).
Hydraulic oil reservoir: 207 gal. (783.6 L).

AUTOMATED CONTROL SYSTEM

Type: Electronic-over-hydraulic.
Controls: GOMACO's exclusive G21 proprietary digital operating system features self-diagnostics for front and rear grade, cross slope, steering, reverse steering for ease of operation. The GOMACO control system features dual grade controls for sensing stringline on both sides of machine simultaneously. Automatic on/off controls for vibrators and tamper bars are activated with machine movement.

TELESCOPING FRAME

Telescoping: Modular frame telescopes on the left side up to 6 ft. 6 in. (1.98 m).

AUGER SYSTEM

Type: Reversible 14 in. (356 mm) diameter hydraulically powered split auger. (3100 series open-front mold)
Auger speed: Up to 66.8 rpm.

TAMPER SYSTEM

Type: Hydraulically powered split vertical tamping system.
Tamper speed: Adjustable up to 120 strokes per minute.

HYDRAULIC SYSTEM

TRACK CIRCUITS

Two & Four-track: Two closed-loop, hydrostatic pumps providing 15.1 gpm (57.2 Lpm) each for a total of 30.2 gpm (114.3 Lpm).

AUGER CIRCUIT

Pumps: Two open-loop, hydraulic vane pumps providing 23.6 gpm (89.3 Lpm) each for a total of 47.2 gpm (178.7 Lpm).

VIBRATOR CIRCUIT

Standard: Two open-loop, hydraulic vane pumps providing 35.3 gpm (133.6 Lpm) each, for a total of 70.6 gpm (267.2 Lpm).
Optional: One open-loop, hydraulic vane pump providing 35.3 gpm (133.6 Lpm).

LIFT CIRCUIT

Pump: One open-loop, pressure-compensated pump providing 38 gpm (143.9 Lpm).

TAMPER CIRCUIT

Pump: One open-loop, hydraulic vane pump providing 21 gpm (79.5 Lpm), up to 10.5 gpm (39.7 Lpm) per circuit.

HYDRAULIC OIL COOLING

Stationary cooler: One stationary cooler with hydraulic fan to cool vibrator, track and auger circuit oil.

FILTRATION

Type: One 10 micron absolute in-tank return filter, 25 psi bypass. Three 100 mesh suction strainers, 3 psi bypass. One 10 micron absolute lift pressure filter, non bypass. Two 16 micron absolute track pump charge pressure filters, non bypass.

SLIPFORM MOLD (3100 series open-front mold)

24 ft. mold: One right-hand drive section, one left-hand drive section, and one power transition adjuster (PTA) section. Balance of inserts per customer specifications. Hydraulically pressure-compensated sideplates with adjustment up to 19 in. (483 mm). Additional insert sections for paving widths up to 32 ft. (9.75 m) optional. Computer-controlled transition adjuster available for transitions.

International 7.5 m mold: One 1 meter right-hand drive section, one 1 meter left-hand drive section, and one 1 meter power transition adjuster (PTA) section. Balance of metric inserts per customer specifications. Hydraulically pressure-compensated sideplates with adjustment up to 483 millimeters. Additional insert sections for paving widths up to 9.75 meters optional. Computer-controlled transition adjuster available for transitions.

VIBRATORS

Type: Hydraulic motor-in-head powering an eccentric weight.

Quantity: 16 vibrators and 16 vibrator circuits.

Optional: 8 additional vibrators and 8 additional vibrator circuits.

TWO-TRACK SYSTEM

Type: Two hydraulically powered, gear-driven crawler tracks.

Overall track length: 11 ft. 10.7 in. (3.62 m) includes track fender or 12 ft. (3.66 m) with optional series 6 tracks.

Track pad width: 15.75 in. (400 mm).

Gearbox reduction: 202:1 gear reduction with two-speed hydraulic motors.

Track speed: Up to 75 fpm (22.9 mpm).

Ground pressure: 18 psi, based on 65,000 lb. (29,484 kg) with weight evenly distributed.

Leg height adjustment: 36 in. (914 mm) hydraulic adjustment.

FOUR-TRACK SYSTEM

Type: Four hydraulically powered, gear-driven crawler tracks.

Overall track length: 7 ft. 11 in. (2.41 m) includes fender.

Track pad width: 15.75 in. (400 mm).

Gearbox reduction: 131:1 gear reduction with two-speed hydraulic motors.

Track speed: Up to 52.8 fpm (16.09 mpm).

Ground pressure: 18.8 psi, based on 83,000 lb. (36,742 kg) with weight evenly distributed.

Leg height adjustment: 36 in. (914 mm) hydraulic adjustment and manual adjustment up to 18 in. (457 mm) for a total height adjustment of 54 in. (1372 mm).

Leg positioning: Each leg has manual leg-mount pivoting arms which allow the leg to pivot up to 19 in. (483 mm) to the outside and up to 15 in. (381 mm) to the inside from the straight-ahead position.

WEIGHTS (approximate, based on standard machine)

Two-track transport weight without mold: 46,000 lbs. (20,866 kg) with series two tracks and two 4 ft. (1.22 m) frame inserts.

Two-track operational weight: 65,000 lbs. (29,484 kg) equipped with series two tracks, 24 ft. (7.32 m) 3100 series open-front mold and two 4 ft. (1.22 m) frame inserts.

Four-track transport weight without mold: 64,000 lbs. (29,030 kg) with series two tracks and two 4 ft. (1.22 m) frame inserts.

Four-track operational weight: 83,000 lbs. (37,649 kg) equipped with with series two tracks, 24 ft. (7.32 m) 3100 series open-front mold and two 4 ft. (1.22 m) frame inserts.

NOTE: Transport and operational weights are variable, depending on number of machine options.

DIMENSIONS (Based on standard machine with series two tracks and 3100 series open-front mold)

Paving width: 12 ft. (3.66 m) to 18 ft. 6 in. (5.64 m) with no inserts needed for frame.

Optional: Paving width to 32 ft. (9.75 m) with additional vibrators and frame inserts.

Two-track operational length: 16 ft. 6 in. (5.03 m).

Two-track operational width: Paving width plus 7 ft. 1 in. (2.16 m).

Two-track operational height: 10 ft. 9.3 in. (3.28 m) with 3100 series open-front mold attached.

Two-track minimum transport length: 19 ft. (5.79 m) with 3100 series open-front mold attached.

Two-track minimum transport width: 11 ft. 11 in. (3.63 m).

Two-track minimum transport height: 10 ft. 1.25 in. (3.08 m) without mold or 10 ft. 9.3 in. (3.28 m) with 3100 series open-front mold attached.

Four-track operational length: 28 ft. 8.25 in. (8.74 m).

Four-track operational width: Paving width plus 6 ft. 5 in. (1.96 m).

Four-track operational height: 10 ft. 4 in. (3.15 m) with 3100 series open-front mold attached.

Four-track minimum transport length: 35 ft. (10.67 m) with series two tracks.

Four-track minimum transport width: 9 ft. 10 in. (3 m).

Four-track minimum transport height: 10 ft. 2 in. (3.1 m) without mold or 10 ft. 7.5 in. (3.24 m) with 3100 series open-front mold attached.

ATTACHMENTS AVAILABLE

VHS, vertical hinged sideplates with hydraulic control and pressure-compensated.

Auto-Float[®] attachment.

Four-corner outrigger system, manual operation.

Four-corner outrigger system, hydraulic powered.

3100 series auger/strike-off mold with 16 in. (406 mm) front auger and 14 in. (356 mm) grout box auger.

5000 series open-front mold with 16 in. (406 mm) auger.

5000 series auger/strike-off mold with 20 in. (508 mm) front auger and 16 in. (406 mm) grout box auger.

Detachable telescoping auger/strike-off.

Air compressor and pressurized tank for air bar inserters.

High-pressure water system.

Low-pressure water system.

Sensor-controlled power transition adjuster (PTA).

Computer-controlled power transition adjuster (PTA).

Hydraulic edge slump control.

Frame extensions.

Grade averaging ski.

IDBI, In-the-pan dowel bar inserter.

Sideplate extensions for bar insertion.

Manual bar inserter.

Air-powered bar inserter.

Hydraulic side bar inserter with vibration.

Frame-mounted bar inserters.

Mold-mounted bar inserters.

Keyway crimper and punch assembly.

Bolt-on male keyway attachments.

Stringless control system.

Other options are available to customize machine to accommodate applications and customer needs.

-- DESIGNED FOR SAFETY --

The GP-2600 is carefully designed to give years of dependable and safe service. The emergency stop buttons are on the operator's console, and on corners of the machine, which are easily accessible from the ground level. Another safety feature includes a backup alarm, which is designed to alert personnel around the machine when the tracks are set to operate in reverse. Other safety features include track guards, warning decals, an operator's manual, and a safety manual. GOMACO machines are also designed to provide the operator with excellent visibility over the entire paving operation.

GOMACO CORPORATION RECOMMENDS THE IMPLEMENTATION OF ALL SAFETY PROCEDURES

GP-2600 FEATURES STATE-OF-THE-ART TECHNOLOGY

- GOMACO's exclusive state-of-the-art G21 proprietary digital operating system features self-diagnostics for front and rear grade, cross slope, steering, reverse steering and for ease of operation. The GOMACO control system features dual grade controls for sensing stringline on both sides of machine simultaneously. Automatic on/off controls for vibrators and tamper bars are activated with machine movement.
- The unique counter-rotation programming allows the paver to turn 360 degrees within its own dimensions, providing excellent job-site mobility.
- The high-performance, low-maintenance, track drive system provides a travel range from a smooth uninterrupted minimum to maximum travel speed. The travel speed of the GP-2600 two-track paver is 75 fpm (22.9 mpm) and 52.8 fpm (16.09 mpm) for the four-track paver.
- The vibrators and the tamper bar are hydraulically-powered, have an automatic on/off control switch, and are activated with machine movement. The vibrator positioning is hydraulically-controlled for ease in start-up and finish.
- The GOMACO quick attach/detach mold system provides quick and easy interchangeability of mold profiles. The "T" beam mounting rail provides more versatility when positioning the mold under the machine. The mold can be positioned anywhere across the width of the "T" beam.
- The engine module is independent of the main frame construction. Fuel and hydraulic reservoir modules are also independent of the paver's main frame. The GP-2600 design provides simple access to all maintenance points for serviceability.

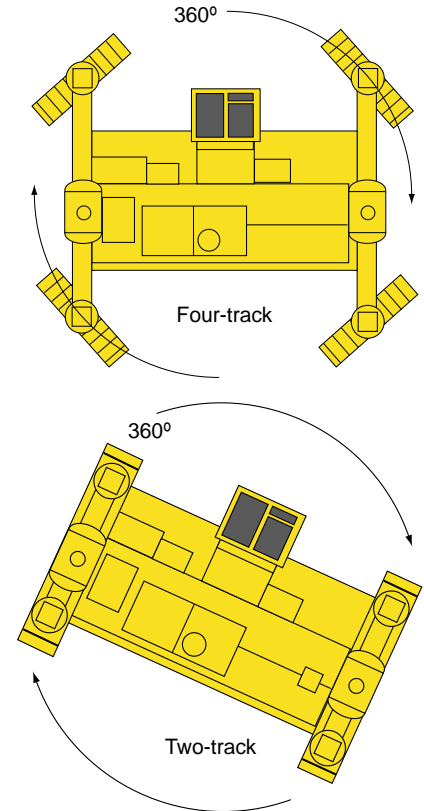

Only GOMACO Offers Exclusive "Smart" Cylinders Featuring Push-Button Steering Control Setup

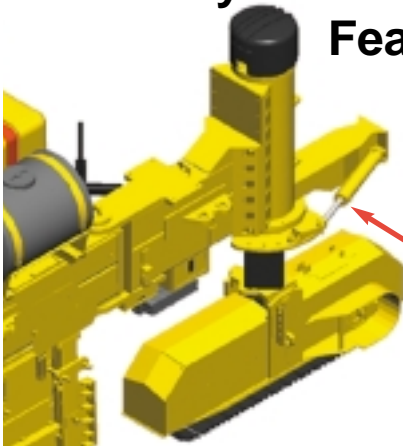

Only GOMACO offers "smart" cylinders to aid in the setup and operation of the four-track paver, especially in minimum-clearance projects.

Steering control has been simplified with **exclusive "smart" cylinders**, used for dependable steering control feedback, eliminating the sprocket, chain, and potentiometer at the top of each leg.

The "smart" cylinder reduces moving

parts and eliminates the physical adjustments to the steering system.

GOMACO's exclusive G21 digital controller now makes it possible to have push-button steering setup. The "smart" cylinders can be taught the desired degree of leg rotation, so that the tracks do not strike any object in minimum-clearance requirements. The operator has the option of overriding this setting.

Cover Photos: Top Photo, HW-110313-D1; Bottom Photo, HW-080412-D6

MANUFACTURED UNDER ONE OR MORE OF THE FOLLOWING U.S. OR FOREIGN PATENTS: 3,299,786; 3,450,011; 3,541,931; 3,779,661; 3,959,977; 4,073,592; 4,136,993; 4,226,917; 4,343,513; 4,360,293; D-266,850; 853,607; 861,819; 954,773; 406,787; 1,147,187; 133,220; D-512,249; 4,717,282; 4,457,645; C-1,110,893; C-1,191,044; 12,890-1-0010; 5,061,115; 7,509,187; 7,509,615; 5,102,267; 5,101,360; 4,954,019; 4,984,639; 5,190,397; 5,209,602; 0,518,535; 2,067,126; 494,257; 69,031,836.7-08; 2,069,516; 5,924,817; 2,833,084 AND PATENTS PENDING.

GOMACO Corporation reserves the right to make improvements in design, material, and/or changes in specifications at any time without notice and without incurring any obligation related to such changes. Performance data is based on averages and may vary from machine to machine.

Printed in U.S.A. © 2006 (1 GC) GOMACO Corporation Order #0405-0A10407



The Worldwide Leader in Concrete Paving Technology

Worldwide Headquarters
GOMACO Corporation
GOMACO International
119 East Highway 175, PO Box 151
Ida Grove, IA USA 51445
Ph: 712-364-3347 Fax: 712.364.3986
International Fax: 712.364.4717
E-mail: info@gomaco.com

GOMACO International Ltd.
769 Buckingham Avenue
Trading Estate, Slough
SL1 4NL Berkshire, England
Ph: 44-1753-821926
Fax: 44.1753.693093
E-mail: pavinguk@gomaco.com

GOMACO International Singapore
#1 Jalan Mat Jambol
Singapore 119497
Ph: 65-6376-0803
Fax: 65.6376.0804
E-mail: tnash@pacific.net.sg

GOMACO International Australia
19 Eustace Street
Aspley, 4034
Brisbane, Queensland
Australia
Ph: 61-07-3630-5000
Fax: 61.07.3630.5888
E-mail: gomaco@bigpond.com

You can always find us at <http://www.gomaco.com/Resources/gp2600.html>